

Put it in the bag

L'originale stand portatile, made in Italy

Icone di stile, in salsa premium

# 1

## Easy transport in suitcase. if it's a fastand, it shows

### IT Portatile, in valigia

Progettare e costruire uno stand o un accessorio per fiere, può sembrare semplice, ma inserirlo in una valigia è cosa ardua e necessita di una progettazione raffinata e complessa.

Ogni componente si incastra e si deve assemblare perfettamente con gli altri, in modo semplice e intuitivo.

La filosofia Fastand coniuga design, alla totale portabilità che grazie alla nuova valigia rigida potrà essere trasportare e assemblato ovunque, in qualsiasi momento..

### EN Portable, in a suitcase

Designing and building a stand or accessory for trade fairs may seem simple, but putting it in a suitcase is arduous and requires a refined and complex design.

Each component fits and must be assembled perfectly with the others, in a simple and intuitive way.

The Fastand philosophy combines design with total portability that thanks to the new rigid suitcase can be transported and assembled anywhere, anytime.

### DE Tragbar in einem Koffer

Es ist üblich zu planen und bauen ein Stand oder ein Zubehör für Messen aber zu fügen alles in einem Koffer ist mühsam und braucht ein raffiniert und komplex Design: das is Fastand Spezialität.

Jede Komponente muss perfekt mit den anderen passen und auf einfache und intuitive Weise.

Die Fastand-Philosophie verbindet Design mit der totale Portabilität; dank des neuen starren Koffers alle Fastand Produkten in jederzeit und überall transportiert und zusammengebaut werden können.

### FR Portable, dans une valise

Concevoir et construire un stand ou un accessoire pour les salons peut sembler simple, mais le mettre dans une valise est ardu et nécessite un design raffiné et complexe.

Chaque composant s'adapte et doit être parfaitement assemblé avec les autres, de manière simple et intuitive.

La philosophie Fastand allie design et portabilité totale qui grâce à la nouvelle valise rigide peut être transportée et assemblée n'importe où, n'importe quand.

### ES Portátil, en una maleta

Diseñar y construir un stand o un accesorio para ferias comerciales puede parecer simple, pero ponerlo en una maleta es difícil y requiere un diseño refinado y complejo. Cada componente encaja y debe ensamblarse perfectamente con los demás, de forma sencilla e intuitiva.

La filosofía Fastand combina diseño con portabilidad total que gracias a la nueva maleta rígida se puede transportar y ensamblar en cualquier lugar, en cualquier momento.

### PT Portátil, em uma mala

Projetar e construir um estande ou acessório para feiras pode parecer simples, mas colocá-lo em uma mala é árduo e requer um design refinado e complexo.

Cada componente se encaixa e deve ser montado perfeitamente com os outros, de maneira simples e intuitiva.

A filosofia Fastand combina design com total portabilidade que, graças à nova mala rígida, pode ser transportada e montada em qualquer lugar, a qualquer hora.

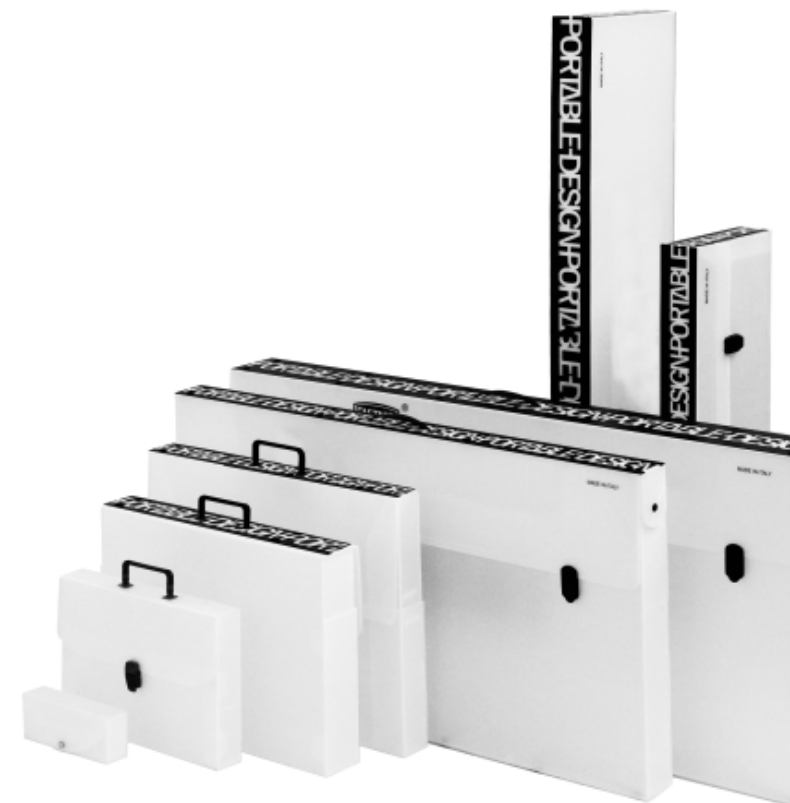

# 2

## High design and quality. weighed and built in Italy

### IT Alto design

I nostri prodotti sono pensati da designers esperti che devono coniugare l'utilità all'aspetto estetico del risultato finale.

Abbiamo molta cura in tutte le fasi produttive e sempre un occhio attento al design dei componenti.

La qualità e il design moderno ci contraddistinguono e ci rendono unici, nel panorama del mercato europeo.

Quindi Fastand coniuga la funzionalità al design.

### EN Pure design

Our products are designed by expert designers who must combine utility with the aesthetic aspect of the final result.

We take great care in all production phases and always pay close attention to the design of the components.

Quality and modern design distinguish us and make us unique in the panorama of the European market.

So Fastand combines functionality with design.

### DE Hohes Design

Unsere Produkte werden von entworfen erfahrene Designer, die Nützlichkeit mit Aussehen Ästhetik des Endergebnisses verbinden. Wir kümmern uns sehr um alles Produktionsphasen und immer sorgfältiges Auge auf das Design der Komponenten.

Die Qualität und das modern Design Zeichnen uns aus und machen uns einzigartig in der Europäische Marktlanschaft. So Fastand verbindet die Funktionalität mit dem Design.

### FR Design avant-gardiste

Nos produits sont conçus par des designers experts qui doivent combiner l'utilité avec l'aspect esthétique du résultat final.

Nous prenons grand soin dans toutes les phases de production et prêtons toujours une attention particulière à la conception des composants.

La qualité et le design moderne nous distinguent et nous rendent uniques dans le panorama du marché européen.

Donc Fastand combine fonctionnalité et design..

### ES Diseño vanguardista

Nuestros productos están diseñados por diseñadores expertos que deben combinar la utilidad con el aspecto estético del resultado final.

Tenemos mucho cuidado en todas las fases de producción y siempre prestamos mucha atención al diseño de los componentes.

La calidad y el diseño moderno nos distinguen y nos hacen únicos en el panorama del mercado europeo.

Entonces Fastand combina funcionalidad con diseño.

### PT Design de vanguarda

Nossos produtos são projetados por designers especializados, que devem combinar utilidade com o aspecto estético do resultado final.

Tomamos muito cuidado em todas as fases da produção e sempre prestamos muita atenção ao design dos componentes.

Qualidade e design moderno nos distinguem e nos tornam únicos no panorama do mercado europeu.

O Fastand combina funcionalidade com design.





# 3

# Componible.

Tool-free, quick and easy assembly



## IT Velocemente

Chi meglio di te sa come presentare la tua azienda e il tuo prodotto?

Da oggi, solo con le tue mani, senza utensili, potrai realizzare tutte le situazioni che durante l'anno si presenteranno.

Presentazioni, convention, fiere, eventi e meeting.

Gli elementi si assemblano facilmente, sono leggeri e completamente componibili.

Lo potrai fare da solo e in tempi davvero veloci: crediamo, infatti, che l'autonomia costruttiva nel settore "exhibit" apra strade e obiettivi nuovi a tutte le imprese innovative e in forte espansione.

## EN Quickly

Who better than you knows how to present your company and your product?

From today, only with your own hands, without tools, you can realize all the situations that will arise during the year.

Presentations, conventions, fairs, events and meetings.

The elements are easily assembled, they are light and fully modular.

You can do it alone and in really fast times: we believe, in fact, that the autonomy of construction in the "exhibit" sector opens up new paths and objectives for all innovative and booming businesses.

## DE Schnell

Wer weiß besser als du wie kann man präsentieren dein Unternehmen und deine Produkte?

Mit Fastand ab heute nur noch mit deinen eigenen Händen und ohne Werkzeuge kannst du schnell verschiedene Situationen lösen. Präsentationen, Kongresse, Messen, Veranstaltungen und Treffen. Die Elemente werden zusammengebaut leicht und voll modular. Du kannst es allein und rechtzeitig tun sehr schnell: wir glauben in der Tat, diese konstruktive Autonomie in den offenen Straßen des Ausstellungssektors und in den neuen Zielen für alle Unternehmen: innovativ und boomend.

## FR Rapidement

Qui mieux que vous sait présenter votre entreprise et votre produit? À partir d'aujourd'hui, uniquement de vos propres mains, sans outils, vous pouvez réaliser toutes les situations qui se présenteront au cours de l'année. Présentations, conventions, foires, événements et réunions.

Les éléments sont faciles à assembler, légers et entièrement modulables. Vous pouvez le faire seul et dans des temps très rapides: nous pensons, en effet, que l'autonomie de la construction dans le secteur "exposition" ouvre de nouvelles voies et de nouveaux objectifs pour toutes les entreprises innovantes et en plein essor.

## ES Rápidamente

¿Quién mejor que tú sabe cómo presentar tu empresa y tu producto?

A partir de hoy, solo con sus propias manos, sin herramientas, puede darse cuenta de todas las situaciones que surgirán durante el año.

Presentaciones, convenciones, ferias, eventos y reuniones.

Los elementos son fáciles de montar, son ligeros y totalmente modulares.

Puede hacerlo solo y en tiempos realmente rápidos: creemos, de hecho, que la autonomía de la construcción en el sector de "exposiciones" abre nuevos caminos y objetivos para todas las empresas innovadoras y en auge.

## PT Rapidamente

Quem melhor do que você sabe como apresentar sua empresa e seu produto?

A partir de hoje, apenas com suas próprias mãos, sem ferramentas, você poderá perceber todas as situações que surgirão durante o ano.

Apresentações, convenções, feiras, eventos e reuniões.

Os elementos são facilmente montados, são leves e totalmente modulares.

Você pode fazer isso sozinho e em tempos muito rápidos: acreditamos, de fato, que a autonomia da construção no setor de "exposições" abre novos caminhos e objetivos para todos os negócios inovadores e em expansão.

# Modular

Small pieces, for big situation

## IT Adattabile

La modularità è un aspetto molto importante dei nostri prodotti. Sono infatti, espandibili e riposizionabili in diverse tipologie di spazio.

Si possono alzare e allungare, aggiungendo o togliendo moduli strutturali.

La filosofia Fastand, permette di organizzare più eventi utilizzando gli stessi prodotti; con un risparmio sia economico che di tempo.

Diminuiscono le tempistiche di preparazione e si mantiene costante la qualità rappresentativa della vostra azienda.

## EN Adaptable

Modularity is a very important aspect of our products. In fact, they are expandable and repositionable in different types of space.

They can be raised and extended by adding or removing structural modules.

The Fastand philosophy allows you to organize multiple events using the same products; with both economic and time savings.

Preparation times decrease and your company's presentation quality remains constant.

## DE Anpassungsfähig

Modularität ist ein sehr wichtiger Aspekt unserer Produkte. Tatsächlich sind sie erweiterbar und können in verschiedenen Raumtypen neu positioniert werden.

Sie können durch Hinzufügen oder Entfernen von Strukturmodulen angehoben und erweitert werden.

Mit der Fastand-Philosophie können Sie mehrere Veranstaltungen mit denselben Produkten organisieren. mit wirtschaftlicher und zeitersparnis.

Die Vorbereitungszeiten verkürzen sich und die Präsentationsqualität Ihres Unternehmens bleibt konstant.

## FR Adaptable

La modularité est un aspect très important de nos produits. En fait, ils sont extensibles et repositionnables dans différents types d'espace.

Ils peuvent être augmentés et étendus en ajoutant ou en supprimant des modules structurels.

La philosophie Fastand vous permet d'organiser plusieurs événements en utilisant les mêmes produits; avec des économies à la fois économiques et de temps.

Les temps de préparation diminuent et la qualité de présentation de votre entreprise reste constante.

## ES Adaptable

La modularidad es un aspecto muy importante de nuestros productos. De hecho, son expandibles y reposicionables en diferentes tipos de espacio.

Se pueden elevar y extender agregando o quitando módulos estructurales.

La filosofía Fastand le permite organizar múltiples eventos utilizando los mismos productos; con ahorros tanto económicos como de tiempo.

Los tiempos de preparación disminuyen y la calidad de presentación de su empresa permanece constante.

## PT Adaptável

A modularidade é um aspecto muito importante dos nossos produtos. De fato, eles são expansíveis e reposicionáveis em diferentes tipos de espaço.

Eles podem ser aumentados e ampliados adicionando ou removendo módulos estruturais. A filosofia Fastand permite organizar vários eventos usando os mesmos produtos; com economia e economia de tempo.

Os tempos de preparação diminuem e a qualidade da apresentação da sua empresa permanece constante.

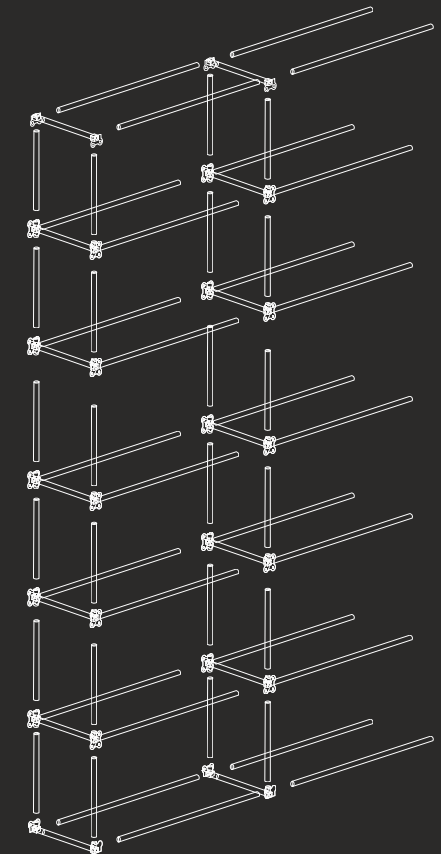

# Icons



- IT. Peso complessivo con valigia
- EN. Total weight with suitcase
- DE. Gesamtgewicht mit Koffer
- FR. Poids total avec valise
- ES. Peso total con maleta
- PT. Peso total com mala



- IT. Tempo stimato di montaggio
- EN. Estimated assembly time
- DE. Geschätzte Montagezeit
- FR. Temps d'assemblage estimé
- ES. Tiempo estimado de montaje
- PT. Tempo estimado de montagem



- IT. Misure della valigia di trasporto
- EN. Transport case measurements
- DE. Transportkoffer-Messungen
- FR. Mesures de caisse de transport
- ES. Mediciones de cajas de transporte
- PT. Medições de malas de transporte



- IT. Garanzia sui componenti
- EN. Parts warranty
- DE. Teilegarantie
- FR. Garantie pièces
- ES. Garantía de piezas
- PT. Garantia de peças



- IT. Novità 2020
- EN. 2020 news
- DE. 2020 Nachrichten
- FR. nouvel article 2020
- ES. Noticias 2020
- PT. Novo artigo 2020



- IT. Realizzato con Aero\*
- EN. Made with Aero\*
- DE. Gemacht mit Aero\*
- FR. Fabriqué avec Aero\*
- ES. Hecho con Aero\*
- PT. Feito com Aero\*



- IT. Realizzato con Fastflex\*
- EN. Made with Fastflex\*
- DE. Gemacht mit Fastflex\*
- FR. Fabriqué avec Fastflex\*
- ES. Hecho con Fastflex\*
- PT. Feito com Fastflex\*



- IT. Sistema avvolgibile brevettato
- EN. Patented roller system
- DE. Patentiertes Rollensystem
- FR. Système de rouleaux breveté
- ES. Sistema de rodillos patentado
- PT. Sistema de rolos patenteado



- IT. Acciaio Inox
- EN. Stainless steel
- DE. Rostfreier Stahl
- FR. Acier inoxydable
- ES. Acero inoxidable
- PT. Aço inoxidável



- IT. Adatto in ambiente esterno
- EN. Usable outdoors
- DE. Im Freien verwendbar
- FR. Utilisable à l'extérieur
- ES. Utilizable al aire libre
- PT. Utilizável ao ar livre



- IT. Sistema frenante brevettato
- EN. Patented brake system
- DE. Patentiertes Bremssystem
- FR. Système de freinage breveté
- ES. sistema de frenos patentado
- PT. Sistema de freio patenteado



- IT. Realizzato in fibra flessibile
- EN. Made of flexible fiber
- DE. Aus flexibler Faser
- FR. Fabriqué en fibre flexible
- ES. Hecho de fibra flexible
- PT. Feito de fibra flexível



- IT. Vernice antibatterica
- EN. Antibacterial paint
- DE. Antibakterielle farbe
- FR. Peinture antibactérienne
- ES. Pintura antibacteriana
- PT. Tinta antibacteriana



- IT. Prodotto scelto da ADI Design
- EN. Product chosen by ADI Design
- DE. Produkt ausgewählt von ADI Design
- FR. Produit choisi par ADI Design
- ES. Producto elegido por ADI Design
- PT. Produto escolhido por ADI Design



# Finishing range



01

Ral 9010  
Pantone Cool grey 1 C

- IT. Bianco puro \_ *Finitura lucida*
- EN. Pure White \_ *Glossy Surface*
- DE. Reines Weiß \_ *Glänzendes Finish*
- FR. Blanc pur \_ *Finition brillante*
- ES. Blanco puro \_ *Acabado brillante*
- PT. Branco puro \_ *Acabamento brilhante*

06

Ral 1016  
Pantone 809 C

- IT. Giallo \_ *Finitura lucida*
- EN. Sulphur yellow \_ *Glossy Surface*
- DE. Gelb \_ *Glänzendes Finish*
- FR. Jaune \_ *Finition brillante*
- ES. Amarillo \_ *Acabado brillante*
- PT. Amarelo \_ *Acabamento brilhante*

08

Ral 3000  
Pantone 1805 C

- IT. Rosso sport \_ *Finitura lucida*
- EN. Sport red \_ *Glossy Surface*
- DE. Roter Sport \_ *Glänzendes Finish*
- FR. Sport rouge \_ *Finition brillante*
- ES. Deporte rojo \_ *Acabado brillante*
- PT. Esporte vermelho \_ *Acabamento brilhante*

04

Ral 9005  
Pantone Black 6 U 2x

- IT. Nero puro \_ *Finitura opaca*
- EN. Pure Black \_ *Matte Surface*
- DE. Reines Schwarz \_ *Mattes Finish*
- FR. Noir pur \_ *Finition mate*
- ES. Negro puro \_ *Acabado mate*
- PT. Preto puro \_ *Acabamento mate*

07

Ral 2003  
Pantone Orange 021 U

- IT. Arancio satinato \_ *Finitura opaca*
- EN. Satin orange \_ *Matte Surface*
- DE. Orange Satin \_ *Mattes Finish*
- FR. Satin orange \_ *Finition mate*
- ES. Naranja satinado \_ *Acabado mate*
- PT. Laranja acetinado \_ *Acabamento mate*

19

Ral 5002  
Pantone Reflex Blue C

- IT. Blu elettrico \_ *Finitura bucciardata*
- EN. Electric Blue \_ *Bushhammered surface*
- DE. Elektrisches Blau \_ *Strukturlack*
- FR. Bleu électrique \_ *finition texturée*
- ES. Azul eléctrico \_ *acabado texturizado*
- PT. Azul elétrico \_ *acabamento texturizado*

91

Ral 9006  
Pantone 877 C

- IT. Argento satinato \_ *Finitura opaca*
- EN. Silver \_ *Matte Surface*
- DE. Silber \_ *Mattes Finish*
- FR. Argent \_ *Finition mate*
- ES. Plata \_ *Acabado mate*
- PT. Prata \_ *Acabamento mate*

05

Ral 5003  
Pantone 282 C

- IT. Blu notte \_ *Finitura lucida*
- EN. Dark blue \_ *Glossy Surface*
- DE. Nachtblau \_ *Glänzendes Finish*
- FR. Bleu nuit \_ *Finition brillante*
- ES. Azul noche \_ *Acabado brillante*
- PT. Noite azul \_ *Acabamento brilhante*

# Create a code

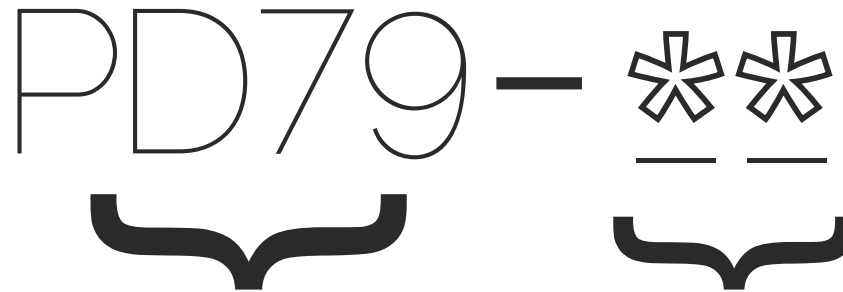

- IT. identificativo prodotto
- EN. product identifier
- DE. Produkerkennung
- FR. identifiant du produit
- ES. identificador de producto
- PT. identificador do produto

- IT. identificativo colore
- EN. color identifier
- DE. Farberkennung
- FR. identification des couleurs
- ES. identificación de color
- PT. identificação de cores

PD79-01



**01** Ral 9010  
Pantone Cool grey 1 C

- IT. Bianco puro \_ *Finitura lucida*
- EN. Pure White \_ *Glossy Surface*
- DE. Reines Weiß \_ *Glänzendes Finish*
- FR. Blanc pur \_ *Finition brillante*
- ES. Blanco puro \_ *Acabado brillante*
- PT. Branco puro \_ *Acabamento brilhante*

PD79-07



**07** Ral 2003  
Pantone Orange 021 U

- IT. Arancio satinato \_ *Finitura opaca*
- EN. Satin orange \_ *Matte Surface*
- DE. Orange Satin \_ *Mattes Finish*
- FR. Satin orange \_ *Finition mate*
- ES. Naranja satinado \_ *Acabado mate*
- PT. Laranja acetinado \_ *Acabamento mate*

PD79-05



**05** Ral 5003  
Pantone 282 C

- IT. Blu notte \_ *Finitura lucida*
- EN. Dark blue \_ *Glossy Surface*
- DE. Nachtblau \_ *Glänzendes Finish*
- FR. Bleu nuit \_ *Finition brillante*
- ES. Azul noche \_ *Acabado brillante*
- PT. Noite azul \_ *Acabamento brilhante*

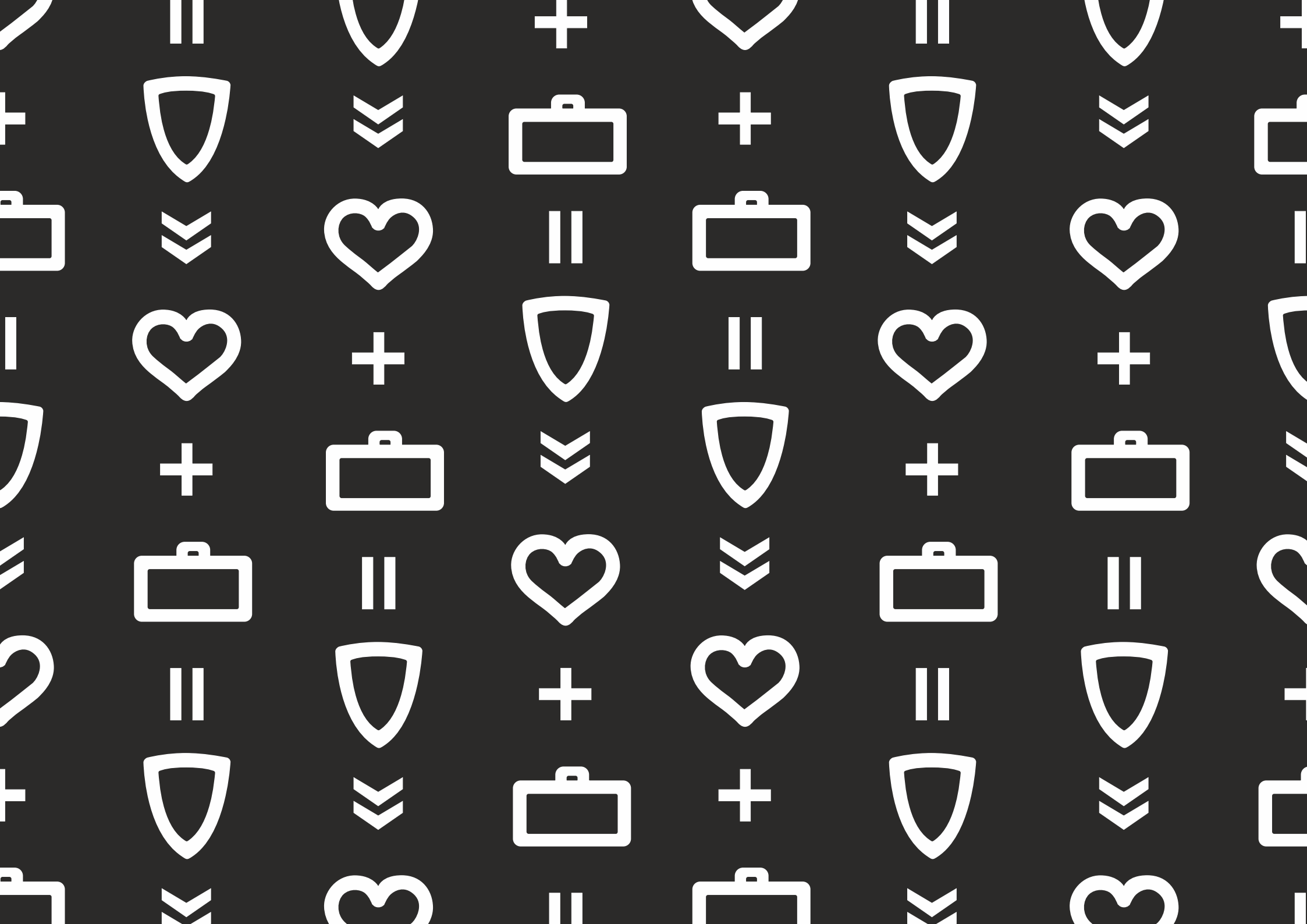

# Maximus



120x56x11  
cm



DK33-01



## IT - Bancone reception

- struttura in alluminio,
- rivestimento metallo verniciato,
- piano appoggio in metallo,
- mensola interna,
- grafica intercambiabile,
- retroilluminazione a Led,
- passacavo,
- valigia rigida

## EN - Reception counter

- aluminum structure,
- painted metal coating,
- metal support surface,
- internal shelf,
- interchangeable graphics,
- LED backlight,
- cable gland,
- rigid suitcase

## DE - Empfangstresen

- Aluminiumstruktur,
- lackierte Metallbeschichtung,
- Metallauflagefläche,
- internes Regal,
- austauschbare Grafiken,
- LED-Hintergrundbeleuchtung,
- Kabelverschraubung,
- fester Koffer

## FR - Comptoir de réception

- structure en aluminium,
- revêtement métallique peint,
- surface de support métallique,
- étagère intérieure,
- graphiques interchangeables,
- rétroéclairage LED,
- presse-étoupe,
- valise rigide

## ES - Mostrador de recepción

- estructura de aluminio,
- revestimiento de metal pintado,
- superficie de soporte metálica,
- estante interno,
- gráficos intercambiables,
- retroiluminación LED,
- prensaestopas,
- maleta rígida

## PT - Balcão de recepção

- estrutura de alumínio,
- revestimento metálico pintado,
- superfície de suporte metálica,
- prateleira interna,
- gráficos intercambiáveis,
- retroiluminação LED,
- prensa-cabos,
- mala rígida

# Maximus, technical details



- IT. In foto: Design morbido e finiture perfette.

- EN. Pictured: Soft design and perfect finishes.

- DE. Im Bild: Weiches Design und perfekte Oberflächen.

- FR. Sur la photo: design doux et finitions parfaites.

- ES. En la foto: diseño suave y acabados perfectos.

- PT. Foto: Design suave e acabamentos perfeitos.



- IT. Il desk reception Maximus è imponente, prestigioso e in puro stilo italiano. Finiture perfette e di alto design, sono i suoi segni riconoscibili. Ideale per ambiente fieristico e eventi prestigiosi.

- EN. The Maximus reception desk is impressive, prestigious and in pure Italian style. Perfect finishes and high design, are its recognizable signs. Ideal for fairgrounds and prestigious events.

- DE. Der Empfang des Maximus-Empfangs ist beeindruckend, prestigeträchtig und im rein italienischen Stil. Perfekte Oberflächen und hohes Design sind die Zeichen erkennbar. Ideal für Messengelände und Veranstaltungen Prestige.

- FR. La réception Maximus est impressionnante, prestigieuse et dans un pur style italien. Des finitions parfaites et un design haut, sont ses signes reconnaissables. Idéal pour les foires et les événements prestigieux.

- ES. El mostrador de recepción de Maximus es impresionante, prestigioso y de puro estilo italiano. Acabados perfectos y alto diseño, son sus signos reconocibles. Ideal para recintos feriales y eventos de prestigio.

- PT. A recepção da Maximus é impressionante, prestigiada e em puro estilo italiano. Acabamentos perfeitos e alto design, são seus sinais reconhecíveis. Ideal para feiras e eventos de prestígio.

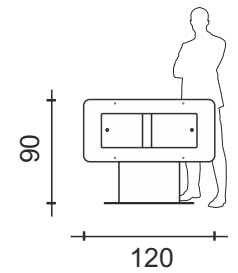
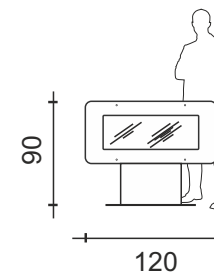
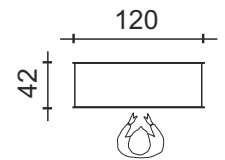

# Podium



DK80-01

## IT - Bancone reception

- struttura in alluminio,
- rivestimento antiurto,
- piano appoggio in metallo,
- mensola interna,
- cassetto porta-oggetti estraibile,
- grafica intercambiabile,
- passacavo,
- valigia rigida.

## EN - Reception counter

- aluminum structure
- shockproof coating
- metal support surface
- internal shelf
- removable drawer for objects
- interchangeable graphics
- fairlead
- hard suitcase

## DE - Empfangstresen

- Aluminiumstruktur
- stoßfeste Beschichtung
- Metall-Auflagefläche
- internes Regal
- herausnehmbare Schublade für Gegenstände
- austauschbare Grafiken
- Leitöse
- harter Koffer

## FR - Comptoir de réception

- structure en aluminium,
- revêtement antichoc,
- surface de support en métal,
- étagère interne,
- tiroir amovible pour objets,
- graphiques interchangeables,
- fairlead
- valise rigide

## ES - Mostrador de recepción

- estructura de aluminio
- revestimiento a prueba de golpes
- superficie de soporte de metal
- estante interno
- cajón extraíble para objetos
- gráficos intercambiables
- pasacables
- maleta rígida

## PT - Balcão de recepção

- estrutura de alumínio
- revestimento à prova de choque
- superfície de suporte de metal
- prateleira interna
- gaveta removível para objetos
- gráficos intercambiáveis
- fairlead
- mala dura



## Podium, accessories



DK02-02

- IT. Porta-tablet universale
- EN. Universal tablet holder
- DE. Universal Tablet-Halter
- FR. Support universel pour tablette
- ES. soporte universal para tableta
- PT. suporte universal para tablet



DK02-08

- IT. Porta-deplianti formato A4
- EN. Brochure holder A4 size
- DE. Prospekthalter A4
- FR. Porte-brochures format A4
- ES. Porta folletos tamaño A4
- PT. Porta-brochura tamanho A4



DK02-05

- IT. Mensole girevole rialzata
- EN. Rotating shelves
- DE. Drehbare Regale
- FR. Étagères tournantes
- ES. Estantes giratorios
- PT. Prateleiras rotativas



DK02-06

- IT. Cartello insegna
- EN. upper sign
- DE. oberes Zeichen
- FR. signe supérieur
- ES. cartel superior
- PT. sinal superior

## Podium, technical details



- IT. Bocchetta passacavo
- EN. Fairlead nozzle
- DE. Fairlead-Düse
- FR. Buse de chaumard
- ES. Agujero pasacables
- PT. Bico Fairlead



- IT. Cassetto estraibile
- EN. removable drawer
- DE. herausnehmbare Schublade
- FR. tiroir amovible
- ES. cajón extraíble
- PT. gaveta removível

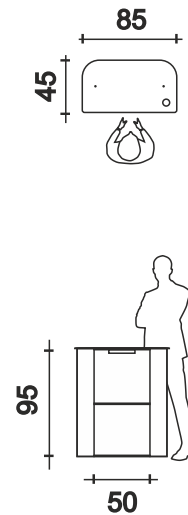
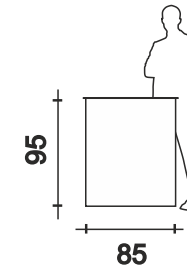

# Nuvola



01 DK72-01



## IT - Bancone reception

- struttura in alluminio,
- rivestimento antiurto,
- piano appoggio in metallo,
- mensola interna,
- cassetto porta-oggetti estraibile,
- grafica intercambiabile,
- passacavo,
- valigia rigida.

## EN - Reception counter

- aluminum structure
- shockproof coating
- metal support surface
- internal shelf
- removable drawer for objects
- interchangeable graphics
- fairlead
- hard suitcase

## DE - Empfangstresen

- Aluminiumstruktur
- stoßfeste Beschichtung
- Metall-Auflagefläche
- internes Regal
- herausnehmbare Schublade für Gegenstände
- austauschbare Grafiken
- Leitöse
- harter Koffer

## FR - Comptoir de réception

- structure en aluminium,
- revêtement antichoc,
- surface de support en métal,
- étagère interne,
- tiroir amovible pour objets,
- graphiques interchangeables,
- fairlead
- valise rigide

## ES - Mostrador de recepción

- estructura de aluminio
- revestimiento a prueba de golpes
- superficie de soporte de metal
- estante interno
- cajón extraíble para objetos
- gráficos intercambiables
- pasacables
- maleta rígida

## PT - Balcão de recepção

- estrutura de alumínio
- revestimento à prova de choque
- superfície de suporte de metal
- prateleira interna
- gaveta removível para objetos
- gráficos intercambiáveis
- fairlead
- mala dura





# Nuvola, accessories



DK02-02

- IT. Porta-tablet universale
- EN. Universal tablet holder
- DE. Universal Tablet-Halter
- FR. Support universel pour tablette
- ES. soporte universal para tableta
- PT. suporte universal para tablet



DK02-08

- IT. Porta-deplianti formato A4
- EN. Brochure holder A4 size
- DE. Prospekhalter A4
- FR. Porte-brochures format A4
- ES. Porta folletos tamaño A4
- PT. Porta-brochura tamanho A4



DK02-05

- IT. Mensole girevole rialzata
- EN. Rotating shelves
- DE. Drehbare Regale
- FR. Étagères tournantes
- ES. Estantes giratorios
- PT. Prateleiras rotativas



DK02-06

- IT. Cartello insegna
- EN. upper sign
- DE. oberes Zeichen
- FR. signe supérieur
- ES. cartel superior
- PT. sinal superior

# Nuvola, technical details



- IT. Bocchetta passacavo
- EN. Fairlead nozzle
- DE. Fairlead-Düse
- FR. Buse de chaumard
- ES. Agujero pasacables
- PT. Bico Fairlead



- IT. Cassetto estraibile
- EN. removable drawer
- DE. herausnehmbare Schublade
- FR. tiroir amovible
- ES. cajón extraíble
- PT. gaveta removível

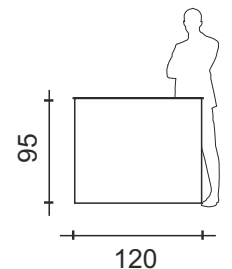
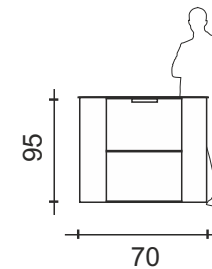
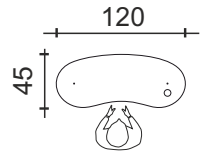

# Sfera



DK43-01



## IT - Bancone reception

- struttura in alluminio,
- rivestimento antiurto,
- piano appoggio in metallo,
- mensola interna,
- grafica intercambiabile,
- passacavo,
- valigia rigida.

## EN - Reception counter

- aluminum structure
- shockproof coating
- metal support surface
- internal shelf
- interchangeable graphics
- fairlead
- hard suitcase

## DE - Empfangstresen

- Aluminiumstruktur
- stoßfeste Beschichtung
- Metall-Auflagefläche
- internes Regal
- austauschbare Grafiken
- Leitöse
- harter Koffer

## FR - Comptoir de réception

- structure en aluminium,
- revêtement antichoc,
- surface de support en métal,
- étagère interne,
- graphiques interchangeables,
- fairlead
- valise rigide

## ES - Mostrador de recepción

- estructura de aluminio
- revestimiento a prueba de golpes
- superficie de soporte de metal
- estante interno
- gráficos intercambiables
- pasacables
- maleta rigida

## PT - Balcão de recepção

- estrutura de alumínio
- revestimento à prova de choque
- superfície de suporte de metal
- prateleira interna
- gráficos intercambiáveis
- fairlead
- mala dura



## Sfera, accessories



DK02-02

- IT. Porta-tablet universale
- EN. Universal tablet holder
- DE. Universeller Tablet-Halter
- FR. Support universel pour tablette
- ES. soporte universal para tableta
- PT. suporte universal para tablet



DK02-08

- IT. Porta-deplianti formato A4
- EN. Brochure holder A4 size
- DE. Prospekthalter A4
- FR. Porte-brochures format A4
- ES. Porta folletos tamaño A4
- PT. Porta-brochura tamanho A4



DK02-05

- IT. Mensole girevole rialzata
- EN. Rotating shelves
- DE. Drehbare Regale
- FR. Étagères tournantes
- ES. Estantes giratorios
- PT. Prateleiras rotativas



PD45-01

- IT. Prolunga piano d'appoggio
- EN. Extension table top
- DE. Tischplattenerweiterung
- FR. Extension de table
- ES. Extensión de mesa
- PT. Extensão do tampo da mesa



DK44-01

- IT. Kit Finale: finitura laterale per desk ( 2 Pz )
- EN. Kit Finale: side finish for desk (2 Pcs)
- DE. End Kit: Seitenverkleidung für Schreibtisch (2 Stück)
- FR. Kit Finale: finition latérale pour bureau (2 pièces)
- ES. Kit Finale: acabado lateral para escritorio (2 piezas)
- PT. Kit Finale: acabamento lateral para mesa (2 peças)

## Sfera, technical details



- IT. Bocchetta passacavo
- EN. Fairlead nozzle
- DE. Fairlead-Düse
- FR. Buse de chaumard
- ES. Agujero pasacables
- PT. Bico Fairlead

- IT. In foto: composizione di 2 moduli
- EN. In the photo: composition of 2 modules
- DE. Auf dem Foto: Zusammensetzung von 2 Modulen
- FR. Sur la photo: composition de 2 modules
- ES. En la foto: composición de 2 módulos.
- PT. Na foto: composição de 2 módulos

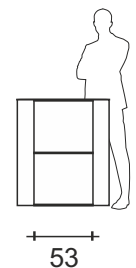
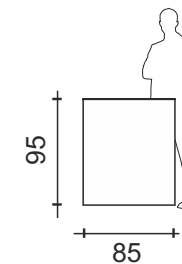
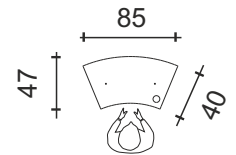

# Scudo



DK45-01



## IT - Bancone reception

- struttura in alluminio,
- rivestimento antiurto,
- piano appoggio in metallo,
- mensola interna,
- grafica intercambiabile,
- passacavo,
- valigia rigida.

## EN - Reception counter

- aluminum structure
- shockproof coating
- metal support surface
- internal shelf
- interchangeable graphics
- fairlead
- hard suitcase

## DE - Empfangstresen

- Aluminiumstruktur
- stoßfeste Beschichtung
- Metall-Auflagefläche
- internes Regal
- austauschbare grafiken
- Leitöse
- harter Koffer

## FR - Comptoir de réception

- structure en aluminium,
- revêtement antichoc,
- surface de support en métal,
- étagère interne,
- graphiques interchangeables,
- fairlead
- valise rigide

## ES - Mostrador de recepción

- estructura de aluminio
- revestimiento a prueba de golpes
- superficie de soporte de metal
- estante interno
- gráficos intercambiables
- pasacables
- maleta rígida

## PT - Balcão de recepção

- estrutura de alumínio
- revestimento à prova de choque
- superfície de suporte de metal
- prateleira interna
- gráficos intercambiáveis
- fairlead
- mala dura



## Scudo, accessories



DK02-02

- IT. Porta-tablet universale
- EN. Universal tablet holder
- DE. Universeller Tablet-Halter
- FR. Support universel pour tablette
- ES. soporte universal para tableta
- PT. suporte universal para tablet



DK02-08

- IT. Porta-deplianti formato A4
- EN. Brochure holder A4 size
- DE. Prospekthalter A4
- FR. Porte-brochures format A4
- ES. Porta folletos tamaño A4
- PT. Porta-brochura tamanho A4



DK02-05

- IT. Mensole girevole rialzata
- EN. Rotating shelves
- DE. Drehbare Regale
- FR. Étagères tournantes
- ES. Estantes giratorios
- PT. Prateleiras rotativas



PD45-01

- IT. Prolunga piano d'appoggio
- EN. Extension table top
- DE. Tischplattenerweiterung
- FR. Extension de table
- ES. Extensión de mesa
- PT. Extensão do tampo da mesa



DK44-01

- IT. Kit Finale: finitura laterale per desk ( 2 Pz )
- EN. Kit Finale: side finish for desk (2 Pcs)
- DE. End Kit: Seitenverkleidung für Schreibtisch (2 Stück)
- FR. Kit Finale: finition latérale pour bureau (2 pièces)
- ES. Kit Finale: acabado lateral para escritorio (2 piezas)
- PT. Kit Finale: acabamento lateral para mesa (2 peças)

## Scudo, technical details



- IT. In foto: lato operatore desk
- EN. In the photo: operator side desk
- DE. Auf dem Foto: Bedienerseite
- FR. Sur la photo: bureau côté opérateur
- ES. En la foto: escritorio del lado del operador
- PT. Na foto: mesa do lado do operador



- IT. Bocchetta passacavo
- EN. Fairlead nozzle
- DE. Fairlead-Düse
- FR. Buse de chaumard
- ES. Agujero pasacables
- PT. Bico Fairlead

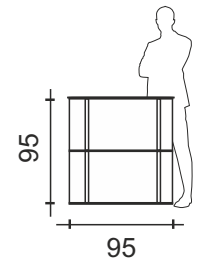
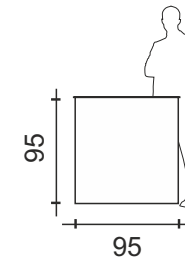
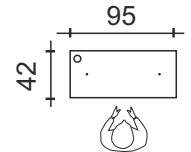

# Sfera + Scudo + kit finale

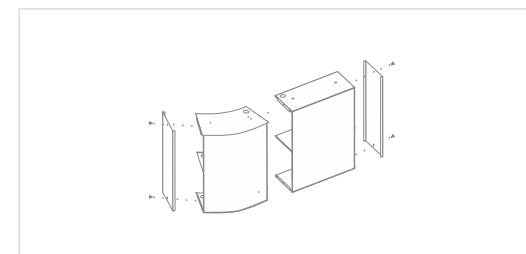

**IT** Abbinando le due tipologie di desk, potrai crea infinite combinazioni e ottenere il desk perfetto in ogni occasione.  
Ricorda sempre, di completare i desk con un Kit Finale; ne aumenta la stabilità e crea una finitura perfetta.

**EN** By combining the two types of desks, you can create infinite combinations and obtain the perfect desk in every occasion.  
Always remember, to complete the desks with a Final Kit; increases its stability and creates a perfect finish.

**DE** Durch die Kombination der beiden Schreibtischtypen können Sie unendlich viele Kombinationen erstellen und bei jeder Gelegenheit den p e r f e k t e n Schreibtischerhalten.  
Denkst du immer daran, die Schreibtische mit einem End Kit zu vervollständigen.  
Das End Kit erhöht die Stabilität und schafft ein perfektes Finish.

**FR** En combinant les deux types de bureaux, vous pouvez créer des combinaisons infinies et obtenir le bureau parfait en toute occasion.  
N'oubliez pas, pour compléter les bureaux avec un kit final; augmente sa stabilité et crée une finition parfaite.

**ES** Al combinar los dos tipos de escritorios, puede crear infinitas combinaciones y obtener el escritorio perfecto en cada ocasión.  
Siempre recuerde completar los escritorios con un Kit Final; aumenta su estabilidad y crea un acabado perfecto.

**PT** Ao combinar os dois tipos de mesa, você pode criar infinitas combinações e obter a mesa perfeita em todas as ocasiões.  
Lembre-se sempre de completar as mesas com um Kit Final; aumenta sua estabilidade e cria um acabamento perfeito.



Sfera



Scudo



kit finale

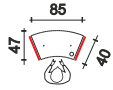

1 Sfera + 1 Kit Finale

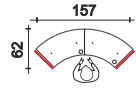

2 Sfera + 1 Kit Finale

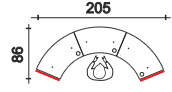

3 Sfera + 1 Kit Finale

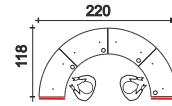

4 Sfera + 1 Kit Finale

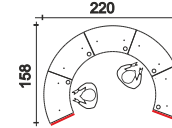

5 Sfera + 1 Kit Finale

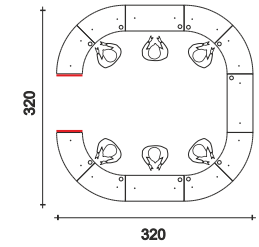

8 Sfera + 3 Scudo + 1 Kit Finale

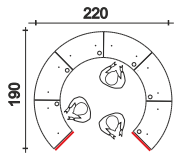

6 Sfera + 1 Kit Finale

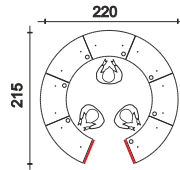

7 Sfera + 1 Kit Finale

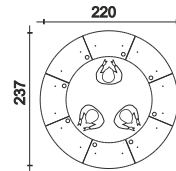

8 Sfera

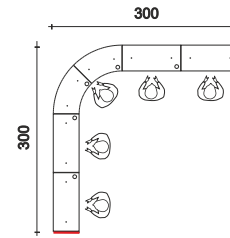

2 Sfera + 4 Scudo + 1 Kit Finale

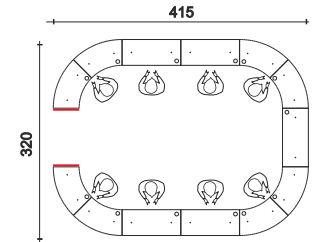

8 Sfera + 5 Scudo + 1 Kit Finale

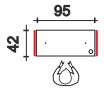

1 Scudo + 1 Kit Finale

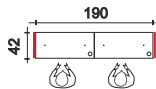

2 Scudo + 1 Kit Finale

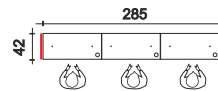

3 Scudo + 1 Kit Finale

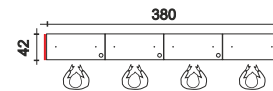

4 Scudo + 1 Kit Finale

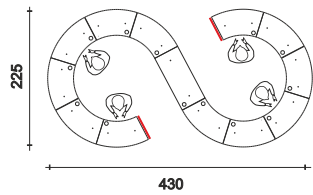

12 Sfera + 1 Scudo + 1 Kit Finale

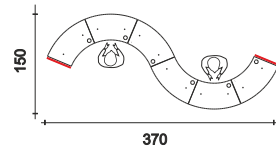

6 Sfera + 1 Kit Finale

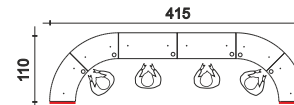

4 Sfera + 2 Scudo + 1 Kit Finale

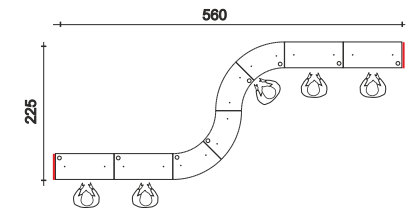

4 Sfera + 4 Scudo + 1 Kit Finale

# Freccia



100x53x6  
cm



DK09-01



**IT** - Bancone reception

- rivestimento antiurto,
- piano appoggio in metallo,
- valigia rigida.

**EN** - Reception counter

- shockproof coating
- metal support surface
- hard suitcase

**DE** - Empfangstresen

- stoßfeste Beschichtung
- Metall-Auflagefläche
- harter Koffer

**FR** - Comptoir de réception

- revêtement antichoc,
- surface de support en métal,
- valise rigide

**ES** - Mostrador de recepción

- revestimiento a prueba de golpes
- superficie de soporte de metal
- maleta rigida

**PT** - Balcão de recepção

- revestimento à prova de choque
- superfície de suporte de metal
- mala dura





## Freccia, accessories



PD30-01

- IT. Cartello insegna
- EN. upper sign
- DE. oberes Zeichen
- FR. signe supérieur
- ES. cartel superior
- PT. sinal superior

- IT. In foto: Design morbido e finiture perfette.

- EN. Pictured: Soft design and perfect finishes.

- DE. Im Bild: Weiches Design und perfekte Oberflächen.

- FR. Sur la photo: design doux et finitions parfaites.

- ES. En la foto: diseño suave y acabados perfectos.

- PT. Foto: Design suave e acabamentos perfeitos.

- IT. Trasportalo con la pratica valigia rigida.

- EN. Transport it with the practical rigid suitcase.

- DE. Transportieren Sie es mit dem praktischen starren Koffer.

- FR. Transportez-le avec la valise rigide pratique.

- ES. Transportarlo con la práctica maleta rígida.

- PT. Transportá-lo com a prática mala rígida.

## Freccia, technical details



- IT. In foto: lato operatore desk
- EN. In the photo: operator side desk
- DE. Auf dem Foto: Bedienerseite
- FR. Sur la photo: bureau côté opérateur
- ES. En la foto: escritorio del lado del operador
- PT. Na foto: mesa do lado do operador

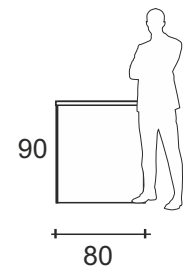
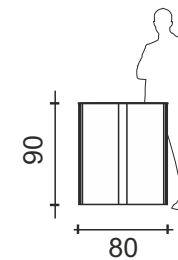
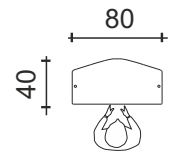

# Scrigno



DK10-01



**IT** - Bancone reception

- rivestimento antiurto,
- piano appoggio in metallo,
- mensola interna,
- grafica intercambiabile,
- valigia rigida.

**EN** - Reception counter

- shockproof coating
- metal support surface
- internal shelf
- interchangeable graphics
- hard suitcase

**DE** - Empfangstresen

- stoßfeste Beschichtung
- Metall-Auflagefläche
- internes Regal
- austauschbare grafiken
- harter Koffer

**FR** - Comptoir de réception

- revêtement antichoc,
- surface de support en métal,
- étagère interne,
- graphiques interchangeables,
- valise rigide

**ES** - Mostrador de recepción

- revestimiento a prueba de golpes
- superficie de soporte de metal
- estante interno
- gráficos intercambiables
- maleta rígida

**PT** - Balcão de recepção

- revestimento à prova de choque
- superfície de suporte de metal
- prateleira interna
- gráficos intercambiáveis
- mala dura



# Scrigno, technical details



- IT. Oltre ad essere il più leggero della categoria, ha ottime doti di portata. Sostiene fino a 50 kg.

- EN. In addition to being the lightest in the category, it has excellent capacity. It supports up to 50 kg.

- DE. Es ist nicht nur das leichteste in dieser Kategorie, sondern verfügt auch über eine hervorragende Kapazität. Es trägt bis zu 50 kg.

- FR. En plus d'être le plus léger de la catégorie, il possède une excellente capacité. Il supporte jusqu'à 50 kg.

- ES. Además de ser el más ligero de la categoría, tiene una excelente capacidad. Soporta hasta 50 kg.

- PT. Além de ser o mais leve da categoria, possui excelente capacidade. Suporta até 50 kg.



- IT. Si apre e si allestisce in due semplici mosse. Il più veloce della categoria.  
- EN. It opens and sets up in two simple steps. The fastest in the category.  
- DE. Es wird in zwei einfachen Schritten geöffnet und eingerichtet. Der schnellste in der Kategorie.  
- FR. Il s'ouvre et s'installe en deux étapes simples. Le plus rapide de la catégorie.  
- ES. Se abre y se configura en dos simples pasos. El más rápido en la categoría.  
- PT. Ele abre e configura em duas etapas simples. O mais rápido da categoria.

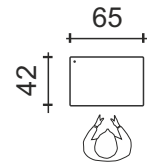

- IT. Trasportalo con la pratica valigia rigida.  
- EN. Transport it with the practical rigid suitcase.  
- DE. Transportieren Sie es mit dem praktischen starren Koffer.  
- FR. Transportez-le avec la valise rigide pratique.  
- ES. Transportarlo con la práctica maleta rígida.  
- PT. Transportá-lo com a prática mala rígida.

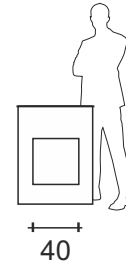
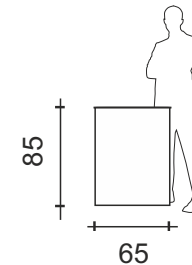

# Velo801



- 01 PD79-01
- 04 PD79-04
- 91 PD79-91
- 05 PD79-05
- 06 PD79-06
- 07 PD79-07
- 08 PD79-08
- 19 PD79-19

**(IT)** - Roll-up 80x200H

- base in metallo verniciato,
- 8 colori disponibili,
- asta in alluminio
- rivestimento intercambiabile
- sistema freno brevettato
- blocco molla brevettato
- valigia rigida.

**(EN)** - Roll-up 80x200H

- painted metal base,
- 8 colors available,
- aluminum rod
- interchangeable coating
- patented brake system
- patented spring block
- rigid suitcase.

**(DE)** - Roll-up 80x200H

- lackierte Metallbasis,
- 8 Farben erhältlich,
- Aluminiumstange
- austauschbare Beschichtung
- Patentiertes Bremssystem
- patentierter Federblock
- starrer Koffer.

**(FR)** - Roll-up 80x200H

- base en métal peint,
- 8 couleurs disponibles,
- tige en aluminium
- revêtement interchangeable
- système de freinage breveté
- bloc ressort breveté
- valise rigide.

**(ES)** - Roll-up 80x200H

- base de metal pintado,
- 8 colores disponibles,
- varilla de aluminio
- revestimiento intercambiabile
- sistema de frenos patentado
- bloque de resorte patentado
- maleta rígida.

**(PT)** - Roll-up 80x200H

- base metálica pintada,
- 8 cores disponíveis,
- vareta de alumínio
- revestimento intercambiável
- sistema de freio patenteado
- bloco de molas patenteado
- mala rígida.



# Velo801, accessories



FS11-91

- IT. Uno: faretto
- EN. Uno: spotlight
- DE. Uno: Rampenlicht
- FR. Uno: lumière
- ES. Uno: foco
- PT. Uno: holofote



RC01-08

- IT. Porta-deplianti formato A4
- EN. Brochure holder A4 size
- DE. Prospekthalter A4
- FR. Porte-brochures format A4
- ES. Porta folletos tamaño A4
- PT. Porta-brochura tamanho A4



RC01-09

- IT. Porta-deplianti formato A5
- EN. Brochure holder A5 size
- DE. Prospekthalter A5
- FR. Porte-brochures format A5
- ES. Porta folletos tamaño A5
- PT. Porta-brochura tamanho A5



RC01-10

- IT. Porta-deplianti formato A6
- EN. Brochure holder A6 size
- DE. Prospekthalter A6
- FR. Porte-brochures format A6
- ES. Porta folletos tamaño A6
- PT. Porta-brochura tamanho A6



RC01-01

- IT. Mensola in plexiglass
- EN. Plexiglass shelf
- DE. Plexiglasregal
- FR. Étagère en plexiglas
- ES. Estante de plexiglas
- PT. Estante em plexiglás

# Velo801, technical details



- IT. In foto: il colore aumenta la personalizzazione
- EN. In the photo: color increases personalization
- DE. Auf dem Foto: die Farbe erhöht die Personalisierung
- FR. Sur la photo: la couleur augmente la personnalisation
- ES. En la foto: el color aumenta la personalización
- PT. Na foto: a cor aumenta a personalização

- IT. In foto: Design morbido e finiture perfette.

- EN. Pictured: Soft design and perfect finishes.

- DE. Im Bild: Weiches Design und perfekte Oberflächen.

- FR. Sur la photo: design doux et finitions parfaites.

- ES. En la foto: diseño suave y acabados perfectos.

- PT. Foto: Design suave e acabamentos perfeitos.

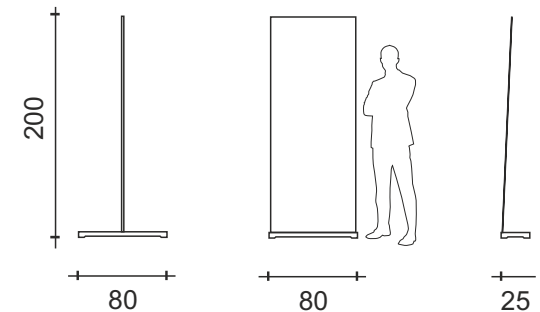
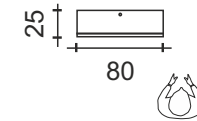

# Velo1201



- 01 PD83-01
- 04 PD83-04
- 91 PD83-91
- 19 PD83-19

## IT - Roll-up 120x200H

- base in metallo verniciato,
- 4 colori disponibili,
- asta in alluminio
- rivestimento intercambiabile
- sistema freno brevettato
- blocco molla brevettato
- valigia rigida.

## EN - Roll-up 120x200H

- painted metal base,
- 4 colors available,
- aluminum rod
- interchangeable coating
- patented brake system
- patented spring block
- rigid suitcase.

## DE - Roll-up 120x200H

- lackierte Metallbasis,
- 4 Farben erhältlich,
- Aluminiumstange
- austauschbare Beschichtung
- Patentiertes Bremssystem
- patentierter Federblock
- starrer Koffer.

## FR - Roll-up 120x200H

- base en métal peint,
- 4 couleurs disponibles,
- tige en aluminium
- revêtement interchangeable
- système de freinage breveté
- bloc ressort breveté
- valise rigide.

## ES - Roll-up 120x200H

- base de metal pintado,
- 4 colores disponibles,
- varilla de aluminio
- revestimiento intercambiabile
- sistema de frenos patentado
- bloque de resorte patentado
- maleta rígida.

## PT - Roll-up 120x200H

- base metálica pintada,
- 4 cores disponíveis,
- vareta de alumínio
- revestimento intercambiável
- sistema de freio patenteado
- bloco de molas patenteado
- mala rígida.





## Velo1201, accessories



FS11-91

- IT. Uno: faretto
- EN. Uno: spotlight
- DE. Uno: Rampenlicht
- FR. Uno: lumière
- ES. Uno: foco
- PT. Uno: holofote



RC01-08

- IT. Porta-deplianti formato A4
- EN. Brochure holder A4 size
- DE. Prospekthalter A4
- FR. Porte-brochures format A4
- ES. Porta folletos tamaño A4
- PT. Porta-brochura tamanho A4



RC01-09

- IT. Porta-deplianti formato A5
- EN. Brochure holder A5 size
- DE. Prospekthalter A5
- FR. Porte-brochures format A5
- ES. Porta folletos tamaño A5
- PT. Porta-brochura tamanho A5



RC01-10

- IT. Porta-deplianti formato A6
- EN. Brochure holder A6 size
- DE. Prospekthalter A6
- FR. Porte-brochures format A6
- ES. Porta folletos tamaño A6
- PT. Porta-brochura tamanho A6



RC01-01

- IT. Mensola in plexiglass
- EN. Plexiglass shelf
- DE. Plexiglasregal
- FR. Étagère en plexiglas
- ES. Estante de plexiglás
- PT. Estante em plexiglás

## Velo1201, technical details

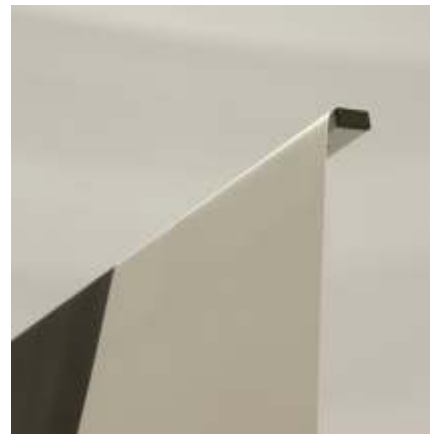

- IT. In foto: il colore aumenta la personalizzazione
- EN. In the photo: color increases personalization
- DE. Auf dem Foto: Farbe erhöht die Personalisierung
- FR. Sur la photo: la couleur augmente la personnalisation
- ES. En la foto: el color aumenta la personalización
- PT. Na foto: a cor aumenta a personalização

- IT. In foto: Design morbido e finiture perfette.

- EN. Pictured: Soft design and perfect finishes.

- DE. Im Bild: Weiches Design und perfekte Oberflächen.

- FR. Sur la photo: design doux et finitions parfaites.

- ES. En la foto: diseño suave y acabados perfectos.

- PT. Foto: Design suave e acabamentos perfeitos.

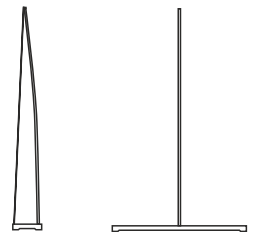
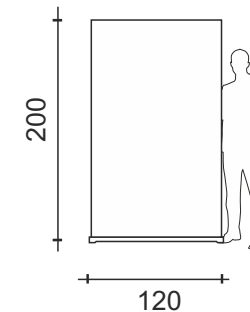
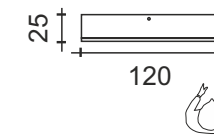

# Velo1501



01 PD84-01

19 PD84-19

IT - Roll-up 150x200H

- base in metallo verniciato,
- 2 colori disponibili,
- asta in alluminio
- rivestimento intercambiabile
- sistema freno brevettato
- blocco molla brevettato
- valigia rigida.

EN - Roll-up 150x200H

- painted metal base,
- 2 colors available,
- aluminum rod
- interchangeable coating
- patented brake system
- patented spring block
- rigid suitcase.

DE - Roll-up 150x200H

- lackierte Metallbasis,
- 2 Farben erhältlich,
- Aluminiumstange
- austauschbare Beschichtung
- Patentiertes Bremssystem
- patentierter Federblock
- starrer Koffer.

FR - Roll-up 150x200H

- base en métal peint,
- 2 couleurs disponibles,
- tige en aluminium
- revêtement interchangeable
- système de freinage breveté
- bloc ressort breveté
- valise rigide.

ES - Roll-up 150x200H

- base de metal pintado,
- 2 colores disponibles,
- varilla de aluminio
- revestimiento intercambiabile
- sistema de frenos patentado
- bloque de resorte patentado
- maleta rigida.

PT - Roll-up 150x200H

- base metálica pintada,
- 2 cores disponíveis,
- vareta de alumínio
- revestimento intercambiável
- sistema de frenos patenteado
- bloco de molas patenteado
- mala rígida.





## Velo1501, accessories



FS11-91

- IT. Uno: faretto
- EN. Uno: spotlight
- DE. Uno: Rampenlicht
- FR. Uno: lumière
- ES. Uno: foco
- PT. Uno: holofote



RC01-08

- IT. Porta-deplianti formato A4
- EN. Brochure holder A4 size
- DE. Prospekthalter A4
- FR. Porte-brochures format A4
- ES. Porta folletos tamaño A4
- PT. Porta-brochura tamanho A4



RC01-09

- IT. Porta-deplianti formato A5
- EN. Brochure holder A5 size
- DE. Prospekthalter A5
- FR. Porte-brochures format A5
- ES. Porta folletos tamaño A5
- PT. Porta-brochura tamanho A5



RC01-10

- IT. Porta-deplianti formato A6
- EN. Brochure holder A6 size
- DE. Prospekthalter A6
- FR. Porte-brochures format A6
- ES. Porta folletos tamaño A6
- PT. Porta-brochura tamanho A6



RC01-01

- IT. Mensola in plexiglass
- EN. Plexiglass shelf
- DE. Plexiglasregal
- FR. Étagère en plexiglas
- ES. Estante de plexiglas
- PT. Estante em plexiglás

## Velo1501, technical details



- IT. In foto: Si monta in poche e semplici mosse.

- EN. In photos: It can be assembled in a few simple steps.

- DE. Auf dem Foto: Es kann in wenigen einfachen Schritten zusammengebaut werden.

- FR. En photos: Il peut être assemblé en quelques étapes simples.



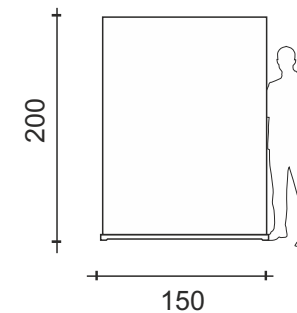
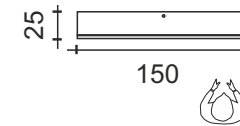

- ES. En fotos: se puede ensamblar en unos simples pasos.

- PT. Nas fotos: pode ser montado em algumas etapas simples.



# Velo802



-  PD80-01
-  PD80-04
-  PD80-91
-  PD80-19

## - Roll-up 100x200H

- doppio telo fronte e retro
- base in metallo verniciato,
- 4 colori disponibili,
- asta in alluminio
- rivestimento intercambiabile
- sistema freno brevettato
- blocco molla brevettato
- valigia rigida.

## - Roll-up 100x200H

- double sheet
- painted metal base,
- 4 colors available,
- aluminum rod
- interchangeable coating
- patented brake system
- patented spring block
- rigid suitcase.

## - Roll-up 100x200H

- Doppelblatt
- lackierte Metallbasis,
- 4 Farben erhältlich,
- Aluminiumstange
- austauschbare Beschichtung
- Patentiertes Bremssystem
- patentierter Federblock
- starrer Koffer.

## - Roll-up 100x200H

- double feuille
- base en métal peint,
- 4 couleurs disponibles,
- tige en aluminium
- revêtement interchangeable
- système de freinage breveté
- bloc ressort breveté
- valise rigide.

## - Roll-up 100x200H

- doble hoja
- base de metal pintado,
- 4 colores disponibles,
- varilla de aluminio
- revestimiento intercambiabile
- sistema de frenos patentado
- bloque de resorte patentado
- maleta rígida.

## - Roll-up 100x200H

- folha dupla
- base metálica pintada,
- 4 cores disponíveis,
- vareta de alumínio
- revestimento intercambiável
- sistema de freio patenteado
- bloco de molas patenteado
- mala rígida.



## Velo802, technical details



- IT. In foto: Si monta in poche e semplici mosse.

- EN. In photos: It can be assembled in a few simple steps.

- DE. In Fotos: Es kann in wenigen einfachen Schritten zusammengebaut werden.

- FR. En photos: Il peut être assemblé en quelques étapes simples.

- ES. En fotos: se puede ensamblar en unos simples pasos.

- PT. Nas fotos: pode ser montado em algumas etapas simples.

- IT. In foto: il colore aumenta la personalizzazione

- EN. In the photo: color increases personalization

- DE. Auf dem Foto: Farbe erhöht die Personalisierung.

- FR. Sur la photo: la couleur augmente la personnalisation

- ES. En la foto: el color aumenta la personalización

- PT. Na foto: a cor aumenta a personalização

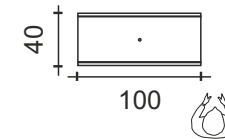

- IT. In foto: Design morbido e finiture perfette.

- EN. Pictured: Soft design and perfect finishes.

- DE. Im Bild: Weiches Design und perfekte Oberflächen.

- FR. Sur la photo: design doux et finitions parfaites.

- ES. En la foto: diseño suave y acabados perfectos.

- PT. Foto: Design suave e acabamentos perfeitos.

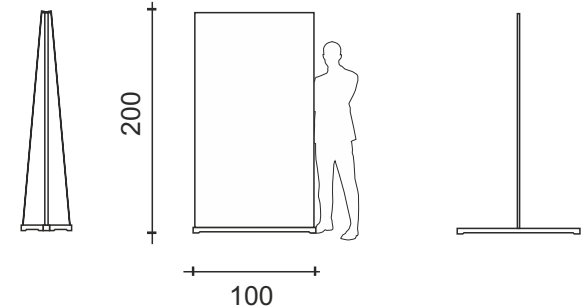

# Punto



01 PD55-01

04 PD55-04



IT - Display

- base in metallo verniciato,
- 2 colori disponibili,
- asta in alluminio
- rivestimento intercambiabile
- valigia rigida.

EN - Display

- painted metal base,
- 2 colors available,
- aluminum rod
- interchangeable coating
- rigid suitcase.

DE - Display

- lackierte Metallbasis,
- 2 Farben erhältlich,
- Aluminiumstange
- austauschbare Beschichtung
- starrer Koffer.

FR - Display

- base en métal peint,
- 2 couleurs disponibles,
- tige en aluminium
- revêtement interchangeable
- valise rigide.

ES - Display

- base de metal pintado,
- 2 colores disponibles,
- varilla de aluminio
- revestimiento intercambiabile
- maleta rígida.

PT - Display

- base metálica pintada,
- 2 cores disponíveis,
- vareta de alumínio
- revestimento intercambiável
- mala rígida.



## Punto, accessories



PD00-01

- IT. Porta-deplianti formato A4
- EN. Brochure holder A4 size
- DE. Prospekthalter A4
- FR. Porte-brochures format A4
- ES. Porta folletos tamaño A4
- PT. Porta-brochura tamanho A4



PD00-06

- IT. Porta-deplianti formato A5
- EN. Brochure holder A5 size
- DE. Prospekthalter A5
- FR. Porte-brochures format A5
- ES. Porta folletos tamaño A5
- PT. Porta-brochura tamanho A5



PD00-07

- IT. Porta-deplianti formato A6
- EN. Brochure holder A6 size
- DE. Prospekthalter A6
- FR. Porte-brochures format A6
- ES. Porta folletos tamaño A6
- PT. Porta-brochura tamanho A6



PD00-12

- IT. Giunzione per pannello
- EN. joint for panel
- DE. Fuge für Platte
- FR. joint pour panneau
- ES. junta para panel
- PT. junta para painel



PD00-22

- IT. Mensola in plexiglass
- EN. Plexiglass shelf
- DE. Plexiglasregal
- FR. Étagère en plexiglas
- ES. Estante de plexiglás
- PT. Estante em plexiglás

## Punto, technical details



- IT. In foto: il colore aumenta la personalizzazione
- EN. In the photo: color increases personalization
- DE. Auf dem Foto: die Farbe erhöht die Personalisierung
- FR. Sur la photo: la couleur augmente la personnalisation
- ES. En la foto: el color aumenta la personalización
- PT. Na foto: a cor aumenta a personalização

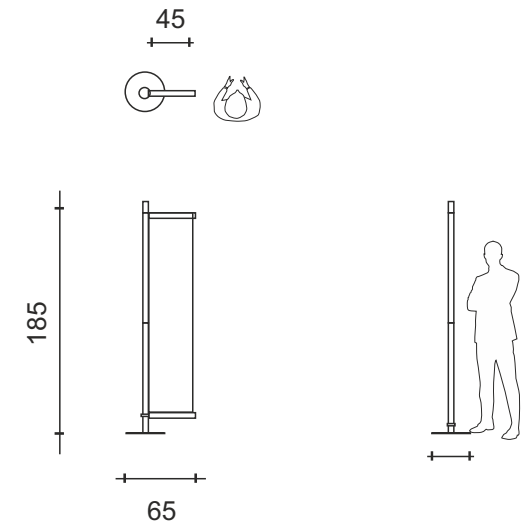

# Vittoria



120x55x11  
cm



01 PD70-01

04 PD70-04

## IT - Porta-poster

- poster su 2 lati
- poster 50x70 cm, intercambiabile
- base in metallo verniciato,
- 2 colori disponibili,
- struttura in alluminio
- frontale in plexiglass
- valigia rigida.

## EN - Poster holder

- poster on 2 sides
- poster 50x70 cm, interchangeable
- painted metal base,
- 2 colors available,
- aluminum structure
- plexiglass front
- rigid suitcase.

## DE - Plakathalter

- Poster auf 2 Seiten
- Poster 50x70 cm, austauschbar
- lackierte Metallbasis,
- 2 Farben erhältlich,
- Aluminiumstruktur
- Plexiglasfront
- starrer Koffer.

## FR - Porte affiche

- affiche sur 2 côtés
- affiche 50x70 cm, interchangeable
- base en métal peint,
- 2 coloris disponibles,
- structure en aluminium
- façade en plexiglas
- valise rigide.

## ES - Porta póster

- póster en 2 lados
- póster 50x70 cm, intercambiable
- base de metal pintado,
- 2 colores disponibles,
- estructura de aluminio
- frente de plexiglas
- maleta rigida.

## PT - Porta-póster

- poster em 2 lados
- póster 50x70 cm, intercambiável
- base metálica pintada,
- 2 cores disponíveis,
- estrutura de alumínio
- frente em plexiglass
- mala rígida.



# Vittoria, technical details



- IT. In foto: Design morbido e finiture perfette.
- EN. Pictured: Soft design and perfect finishes.
- DE. Im Bild: Weiches Design und perfekte Oberflächen.
- FR. Sur la photo: design doux et finitions parfaites.
- ES. En la foto: diseño suave y acabados perfectos.
- PT. Foto: Design suave e acabamentos perfeitos.



- IT. In foto: Si monta in poche e semplici mosse.
- EN. In photos: It can be assembled in a few simple steps.
- DE. In Fotos: Es kann in wenigen einfachen Schritten zusammengebaut werden.
- FR. En photos: Il peut être assemblé en quelques étapes simples.
- ES. En fotos: se puede ensamblar en unos simples pasos.
- PT. Nas fotos: pode ser montado em algumas etapas simples.

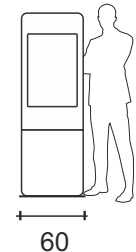
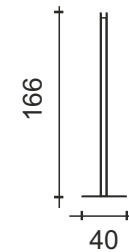
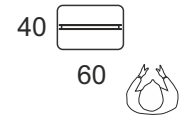

POSTER  
100  
X  
70

# Lineo



01 <sup>01</sup> EE62-01

04 EE62-04

08 EE62-08

**IT** - Parete auto-portante

- struttura in alluminio,
- giunzioni in metallo,
- tensionatori in nylon
- basi in metallo verniciato,
- disponibile in 3 colori
- rivestimento in telo,
- grafica intercambiabile,
- valigia rigida.

**EN** - Self-supporting wall

- aluminum structure,
- metal joints,
- nylon tensioners
- painted metal bases,
- available in 3 colors
- fabric cover,
- interchangeable graphics,
- rigid suitcase.

**DE** - Selbsttragende Wand

- Aluminiumstruktur,
- Metallverbindungen,
- Nylonspanner
- lackierte Metallsockel,
- in 3 Farben erhältlich
- Stoffbezug,
- austauschbare Grafiken,
- starrer Koffer.

**FR** - Mur autoportant

- structure en aluminium,
- joints métalliques,
- tendeurs en nylon
- bases en métal peint,
- disponible en 3 couleurs
- housse en tissu,
- graphiques interchangeables,
- valise rigide.

**ES** - Pared autoportante

- estructura de aluminio,
- juntas metálicas,
- tensores de nylon
- bases metálicas pintadas,
- disponible en 3 colores
- cubierta de tela,
- gráficos intercambiables,
- maleta rígida.

**PT** - Parede autoportante

- estrutura de alumínio,
- juntas metálicas,
- tensores de nylon
- bases metálicas pintadas,
- disponível em 3 cores
- capa de tecido,
- gráficos intercambiáveis,
- mala rígida.





## Lineo, accessories



PD00-01

- IT. Porta-deplianti formato A4
- EN. Brochure holder A4 size
- DE. Prospekthalter A4
- FR. Porte-brochures format A4
- ES. Porta folletos tamaño A4
- PT. Porta-brochura tamanho A4



PD00-06

- IT. Porta-deplianti formato A5
- EN. Brochure holder A5 size
- DE. Prospekthalter A5
- FR. Porte-brochures format A5
- ES. Porta folletos tamaño A5
- PT. Porta-brochura tamanho A5



PD00-07

- IT. Porta-deplianti formato A6
- EN. Brochure holder A6 size
- DE. Prospekthalter A6
- FR. Porte-brochures format A6
- ES. Porta folletos tamaño A6
- PT. Porta-brochura tamanho A6



PD00-12

- IT. Mensola in plexiglass
- EN. Plexiglass shelf
- DE. Plexiglasregal
- FR. Étagère en plexiglas
- ES. Estante de plexiglas
- PT. Estante em plexiglás



PD00-22

- IT. Giunzione per pannello
- EN. joint for panel
- DE. Fuge für Platte
- FR. joint pour panneau
- ES. junta para panel
- PT. junta para painel

## Lineo, technical details



- IT. In foto: Design morbido e finiture perfette.

- EN. Pictured: Soft design and perfect finishes.

- DE. Im Bild: Weiches Design und perfekte Oberflächen.

- FR. Sur la photo: design doux et finitions parfaites.

- ES. En la foto: diseño suave y acabados perfectos.

- PT. Foto: Design suave e acabamentos perfeitos.

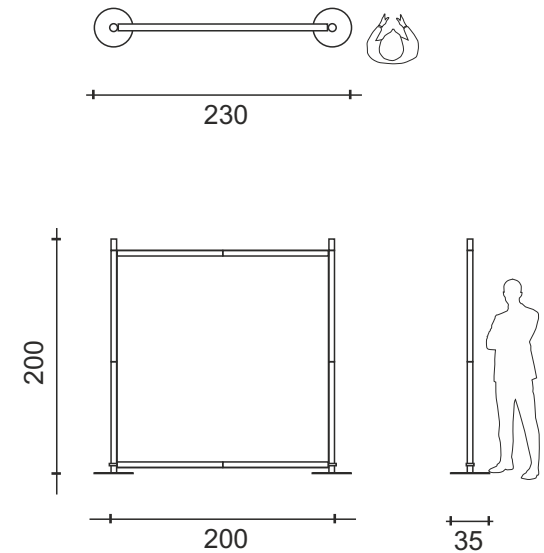

# Vertigo



EE16-01



**IT** - Parete rotante

- struttura in alluminio estensibile,
- giunto snodato in metallo,
- tensionatori in Fibra elastica
- base in metallo verniciato,
- rivestimento in telo,
- grafica intercambiabile,
- valigia rigida.

**EN** - Rotating wall

- extensible aluminum structure,
- articulated joint in metal,
- elastic fiber tensioners
- painted metal base,
- fabric cover,
- interchangeable graphics,
- rigid suitcase.

**DE** - Drehende Wand

- dehbare Aluminiumstruktur,
- Gelenk in Metall,
- elastische Fasertensioner
- lackierte Metallbasis,
- Stoffbezug,
- austauschbare Grafiken,
- starrer Koffer.

**FR** - Mur tournant

- structure en aluminium extensible,
- joint articulé en métal,
- tendeurs de fibres élastiques
- base en métal peint,
- housse en tissu,
- graphiques interchangeables,
- valise rigide.

**ES** - Pared giratoria

- estructura de aluminio extensible,
- articulación articulada en metal,
- tensores elásticos de fibra
- base de metal pintado,
- cubierta de tela,
- gráficos intercambiables,
- maleta rígida..

**PT** - Parede rotativa

- estrutura extensível de alumínio,
- junta articulada em metal,
- tensores de fibra elástica
- base metálica pintada,
- capa de tecido,
- gráficos intercambiáveis,
- mala rígida.



## Lineo, technical details

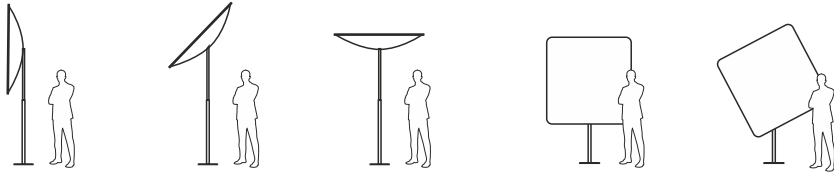

- IT. Grazie al giunto snodato, assume molteplici posizioni e si adatta a tutte le situazioni. Ideale per eventi e fiere.

- EN. Thanks to the articulated joint, it assumes multiple positions and adapts to all situations. Ideal for events and fairs.

- DE. Dank des Gelenkgelenks nimmt es mehrere Positionen ein und passt sich allen Situationen an. Ideal für Veranstaltungen und Messen.

- FR. Grâce à l'articulation articulée, il assume plusieurs positions et s'adapte à toutes les situations. Idéal pour les événements et les foires.

- ES. Gracias a la articulación articulada, asume múltiples posiciones y se adapta a todas las situaciones. Ideal para eventos y ferias.

- PT. Graças à articulação articulada, assume múltiplas posições e se adapta a todas as situações. Ideal para eventos e feiras.



- IT. In foto: Si monta in poche e semplici mosse.

- EN. In photos: It can be assembled in a few simple steps.

- DE. Auf den Fotos: Es kann in wenigen einfachen Schritten zusammengesetzt werden.

- FR. En photos: Il peut être assemblé en quelques étapes simples.

- ES. En fotos: se puede ensamblar en unos simples pasos.

- PT. Nas fotos: pode ser montado em algumas etapas simples.

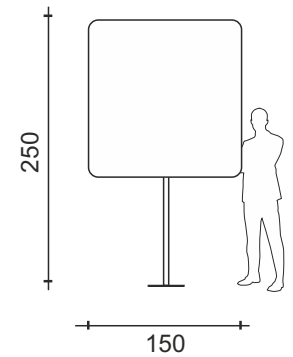
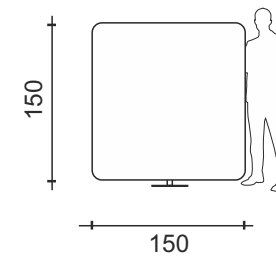
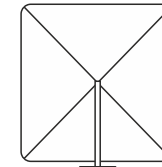

# Hidra



120x56x11  
cm

01  DK30-01



**IT** - Bancone espositivo

- struttura in alluminio
- rivestimento plastico,
- vetrina in plexiglass
- piano appoggio in plexiglass,
- illuminazione vetrina a Led
- mensola interna,
- antine apribili,
- valigia rigida.

**EN** - Exhibition counter

- aluminum structure
- plastic coating,
- plexiglass showcase
- plexiglass support surface,
- Led showcase lighting
- internal shelf,
- opening doors,
- rigid suitcase.

**DE** - Ausstellungsschalter

- Aluminiumstruktur
- Kunststoffbeschichtung,
- Plexiglasvitrine
- Plexiglas-Auflagefläche,
- LED-Vitrinenbeleuchtung
- Innenregal,
- Türen öffnen,
- starrer Koffer.

**FR** - Comptoir d'exposition

- structure en aluminium
- revêtement plastique,
- vitrine en plexiglas
- surface d'appui en plexiglas,
- Éclairage de vitrine LED
- étagère intérieure,
- ouverture des portes,
- valise rigide.

**ES** - Mostrador de la exposición

- estructura de aluminio
- revestimiento de plástico,
- vitrina de plexiglas
- superficie de soporte de plexiglas,
- Iluminación led de escaparate
- estante interno,
- abriendo puertas,
- maleta rígida.

**PT** - Balcão de exposições

- estrutura de alumínio
- revestimento de plástico,
- vitrine de plexiglas
- superfície de suporte de plexiglas,
- Iluminação de mostruário LED
- prateleira interna,
- abrir portas,
- mala rígida.



## Hidra, technical details



- IT. Elegante e funzionale, grazie alla vetrina in plexiglass.

- EN. Elegant and functional, thanks to the plexiglass display cabinet.

- DE. Elegant und funktional dank der Plexiglasvitrine.

- FR. Éléгант et fonctionnel, grâce à la vitrine en plexiglas.

- ES. Elegante y funcional, gracias a la vitrina de plexiglás.

- PT. Elegante e funcional, graças ao armário de exibição de acrílico.



- IT. Pratiche antine, per creazione di un ampio vano porta-oggetti.

- EN. Practical doors, for the creation of a large storage compartment.

- DE. Praktische Türen zur Schaffung eines großen Ablagefachs.

- FR. Portes pratiques, pour la création d'un grand compartiment de rangement.

- ES. Puertas prácticas, para la creación de un gran compartimento de almacenamiento.

- PT. Portas práticas, para a criação de um grande compartimento de arrumação.

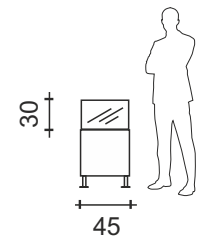
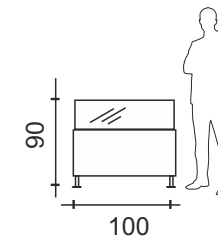
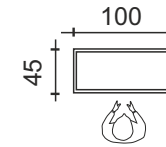

# Talento Quadro



01 DK11-01  
h50 cm

01 DK12-01  
h75 cm

01 DK13-01  
h100 cm

IT - Espositore prodotti

- rivestimento antiurto,
- piano appoggio in metallo,
- grafica intercambiabile,
- valigia rigida.

EN - Products display

- shockproof coating
- metal support surface
- interchangeable graphics
- hard suitcase

DE - Produktanzeige

- stoßfeste Beschichtung
- Metall-Auflagefläche
- austauschbare grafiken
- harter Koffer

FR - Affichage du produit

- revêtement antichoc,
- surface de support en métal,
- graphiques interchangeables,
- valise rigide

ES - Exhibición del producto

- revestimiento a prueba de golpes
- superficie de soporte de metal
- gráficos intercambiables
- maleta rigida

PT - Exposição do produto

- revestimento à prova de choque
- superfície de suporte de metal
- gráficos intercambiáveis
- mala dura

# Talento Quadro, technical details



- IT. In foto: Design morbido e finiture perfette.

- EN. Pictured: Soft design and perfect finishes.

- DE. Im Bild: Weiches Design und perfekte Oberflächen.

- FR. Sur la photo: design doux et finitions parfaites.

- ES. En la foto: diseño suave y acabados perfectos.

- PT. Foto: Design suave e acabamentos perfeitos.



- IT. In foto: Si monta in poche e semplici mosse. Disponibile in 3 differenti altezze.

- EN. In photos: It can be assembled in a few simple steps. Available in 3 different heights.

- DE. Auf den Fotos: Es kann in wenigen einfachen Schritten zusammengebaut werden. Erhältlich in 3 verschiedenen Höhen.

- FR. En photos: Il peut être assemblé en quelques étapes simples. Disponible en 3 hauteurs différentes.

- ES. En fotos: se puede ensamblar en unos simples pasos. Disponible en 3 alturas diferentes.

- PT. Nas fotos: pode ser montado em algumas etapas simples. Disponível em 3 alturas diferentes.

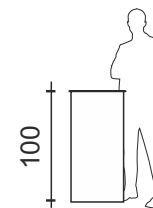

DK13-01  
h100 cm

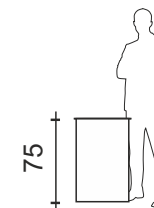

DK12-01  
h75 cm

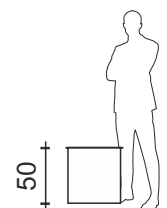
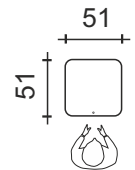

DK11-01  
h50 cm

# Talento Tondo



100x53x6  
cm



01 DK15-01  
h50 cm

01 DK16-01  
h75 cm

01 DK17-01  
h100 cm

**IT** - Espositore prodotti

- rivestimento antiurto,
- piano appoggio in metallo,
- grafica intercambiabile,
- valigia rigida.

**EN** - Products display

- shockproof coating
- metal support surface
- interchangeable graphics
- hard suitcase

**DE** - Produktanzeige

- stoßfeste Beschichtung
- Metall-Auflagefläche
- austauschbare grafiken
- harter Koffer

**FR** - Affichage du produit

- revêtement antichoc,
- surface de support en métal,
- graphiques interchangeables,
- valise rigide

**ES** - Exhibición del producto

- revestimiento a prueba de golpes
- superficie de soporte de metal
- gráficos intercambiables
- maleta rigida

**PT** - Exposição do produto

- revestimento à prova de choque
- superfície de suporte de metal
- gráficos intercambiáveis
- mala dura



# Talento Tondo, technical details



- IT. In foto: Design morbido e finiture perfette.

- EN. Pictured: Soft design and perfect finishes.

- DE. Im Bild: Weiches Design und perfekte Oberflächen.

- FR. Sur la photo: design doux et finitions parfaites.

- ES. En la foto: diseño suave y acabados perfectos.

- PT. Foto: Design suave e acabamentos perfeitos.



- IT. In foto: Si monta in poche e semplici mosse. Disponibile in 3 differenti altezze.

- EN. In photos: It can be assembled in a few simple steps. Available in 3 different heights.

- DE. In Fotos: Es kann in wenigen einfachen Schritten zusammengebaut werden. Erhältlich in 3 verschiedenen Höhen.

- FR. En photos: Il peut être assemblé en quelques étapes simples. Disponible en 3 hauteurs différentes.

- ES. En fotos: se puede ensamblar en unos simples pasos. Disponible en 3 alturas diferentes.

- PT. Nas fotos: pode ser montado em algumas etapas simples. Disponível em 3 alturas diferentes.

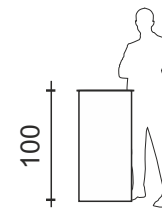

DK17-01  
h100 cm



DK16-01  
h75 cm

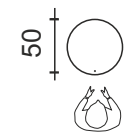

DK15-01  
h50 cm

# Maranello



01 PD12-01

04 PD12-04

19 PD12-19

**IT** - Espositore curvilineo

- frontale in metallo verniciato,
- base in metallo verniciato,
- cavetto in acciaio,
- morsetto cromato,
- molti accessori disponibili
- valigia rigida.

**EN** - Curvilinear display

- painted metal front,
- painted metal base,
- steel cable,
- chromed clamp,
- many accessories available
- rigid suitcase.

**DE** - Krummlinige Anzeige

- lackierte Metallfront,
- lackierte Metallbasis,
- Stahlkabel,
- verchromte Klemme,
- viel Zubehör erhältlich
- starrer Koffer.

**FR** - Affichage curviligne

- façade en métal peint,
- base en métal peint,
- câble en acier,
- pince chromée,
- de nombreux accessoires disponibles
- valise rigide.

**ES** - Pantalla curvilínea

- frente de metal pintado,
- base de metal pintado,
- cable de acero,
- abrazadera cromada,
- muchos accesorios disponibles
- maleta rígida.

**PT** - Tela curvilínea

- frente em metal pintado,
- base metálica pintada,
- cabo de aço,
- braçadeira cromada,
- muitos acessórios disponíveis
- mala rígida.

# Maranello, accessories



PD08-01

- IT. Porta-deplianti formato A4
- EN. Brochure holder A4 size
- DE. Prospekthalter A4
- FR. Porte-brochures format A4
- ES. Porta folletos tamaño A4
- PT. Porta-brochura tamanho A4



PD08-06

- IT. Porta-deplianti formato A5
- EN. Brochure holder A5 size
- DE. Prospekthalter A5
- FR. Porte-brochures format A5
- ES. Porta folletos tamaño A5
- PT. Porta-brochura tamanho A5



PD08-07

- IT. Porta-deplianti formato A6
- EN. Brochure holder A6 size
- DE. Prospekthalter A6
- FR. Porte-brochures format A6
- ES. Porta folletos tamaño A6
- PT. Porta-brochura tamanho A6

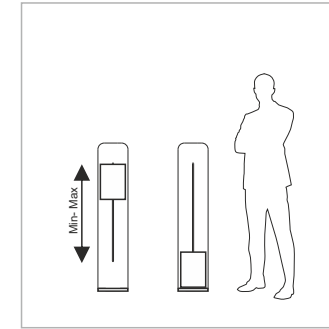

- IT. Regolazione verticale degli accessori
- EN. Vertical adjustment of accessories
- DE. Vertikale Einstellung des Zubehörs
- FR. Réglage vertical des accessoires
- ES. Ajuste vertical de accesorios
- PT. Ajuste vertical de acessórios



PD08-11

- IT. porta-sacchetti
- EN. door-bags
- DE. Tür-Taschen
- FR. porte-sacs
- ES. cuelga bolsas
- PT. porta-malas



PD08-03

- IT. Mensola in plexiglass A4
- EN. A4 Plexiglass shelf
- DE. A4 Plexiglasregal
- FR. Étagère en plexiglas A4
- ES. Estante de plexiglás A4
- PT. Estante em plexiglás A4



PD08-05

- IT. Mensola in plexiglass
- EN. Plexiglass shelf
- DE. Plexiglasregal
- FR. Étagère en plexiglas
- ES. Estante de plexiglás
- PT. Estante em plexiglás



PD08-02

- IT. Porta-foglio A4
- EN. A4 sheet holder
- DE. A4 Blatthalter
- FR. Porte-feuille A4
- ES. Porta hojas A4
- PT. Porta-folhas A4

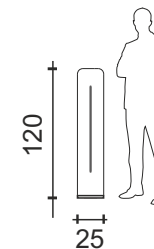
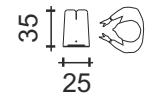

# Contatto



01 SA15-01

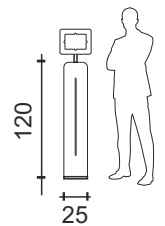
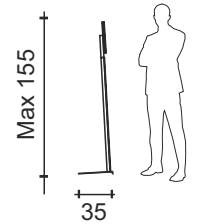
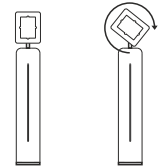

**IT** - Espositore Tablet

- struttura in alluminio,
- frontale in metallo verniciato,
- base in metallo verniciato,
- tasca girevole universale per Tablet ,
- valigia rigida.

**EN** - Tablet display

- aluminum structure,
- painted metal front,
- painted metal base,
- universal rotating pocket for Tablet,
- rigid suitcase.

**DE** - Tablet-Anzeige

- Aluminiumstruktur,
- lackierte Metallfront,
- lackierte Metallbasis,
- universelle Drehtasche für Tablet,
- starrer Koffer.

**FR** - Affichage sur tablette

- structure en aluminium,
- façade en métal peint,
- base en métal peint,
- poche rotative universelle pour tablette,
- valise rigide.

**ES** - Pantalla de la tableta

- estructura de aluminio,
- frente de metal pintado,
- base de metal pintado,
- soporte giratorio universal para tableta,
- maleta rígida.

**PT** - Tela para tablet

- estrutura de alumínio,
- frente em metal pintado,
- base metálica pintada,
- bolso rotativo universal para tablet,
- mala rígida.

# Visione



120x56x11  
Cm



01 SA64-01

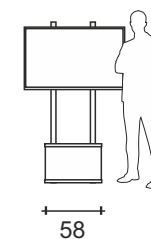
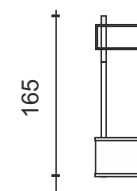
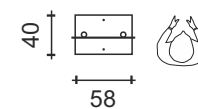

**IT** - Espositore Tv

- basi in metallo
- struttura in alluminio,
- piastra Tv universale fino a 55",
- grafica intercambiabile,
- valigia rigida.

**EN** - Tv display

- metal bases
- aluminum structure,
- universal TV plate up to 55",
- interchangeable graphics,
- rigid suitcase.

**DE** - Fernsehbildschirm

- Metallbasen
- Aluminiumstruktur,
- Universal-TV-Platte bis 55",
- austauschbare Grafiken,
- starrer Koffer.

**FR** - Affichage TV

- bases métalliques
- structure en aluminium,
- plaque TV universelle jusqu'à 55",
- graphiques interchangeables,
- valise rigide.

**ES** - Pantalla de TV

- bases de metal
- estructura de aluminio,
- placa de TV universal de hasta 55",
- gráficos intercambiables,
- maleta rígida.

**PT** - Exibição de TV

- bases metálicas
- estrutura de alumínio,
- placa de TV universal de até 55",
- gráficos intercambiáveis,
- mala rígida.

# Vetra



01 VE18-01

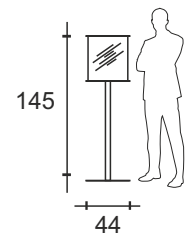
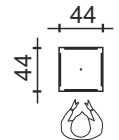

IT - Vetrina

- struttura in alluminio,
- piano appoggio in metallo,
- rivestimento in plexiglass,
- valigia rigida.

EN - Shop window

- aluminum structure,
- metal support surface,
- plexiglass coating,
- rigid suitcase.

DE - Vitrine

- Aluminiumstruktur,
- Metallträgerfläche,
- Plexiglasbeschichtung,
- starrer Koffer.

FR - Vitrine

- structure en aluminium,
- surface de support métallique,
- revêtement plexiglas,
- valise rigide.

ES - Escaparate

- estructura de aluminio,
- superficie de soporte metálica,
- revestimiento de plexiglas,
- maleta rígida.

PT - Mostruário

- estrutura de alumínio,
- superfície de suporte de metal,
- revestimento de plexiglass,
- mala rígida.



